

VERTIFLO PUMP COMPANY Dimensions

814 Duplex Sump Pump

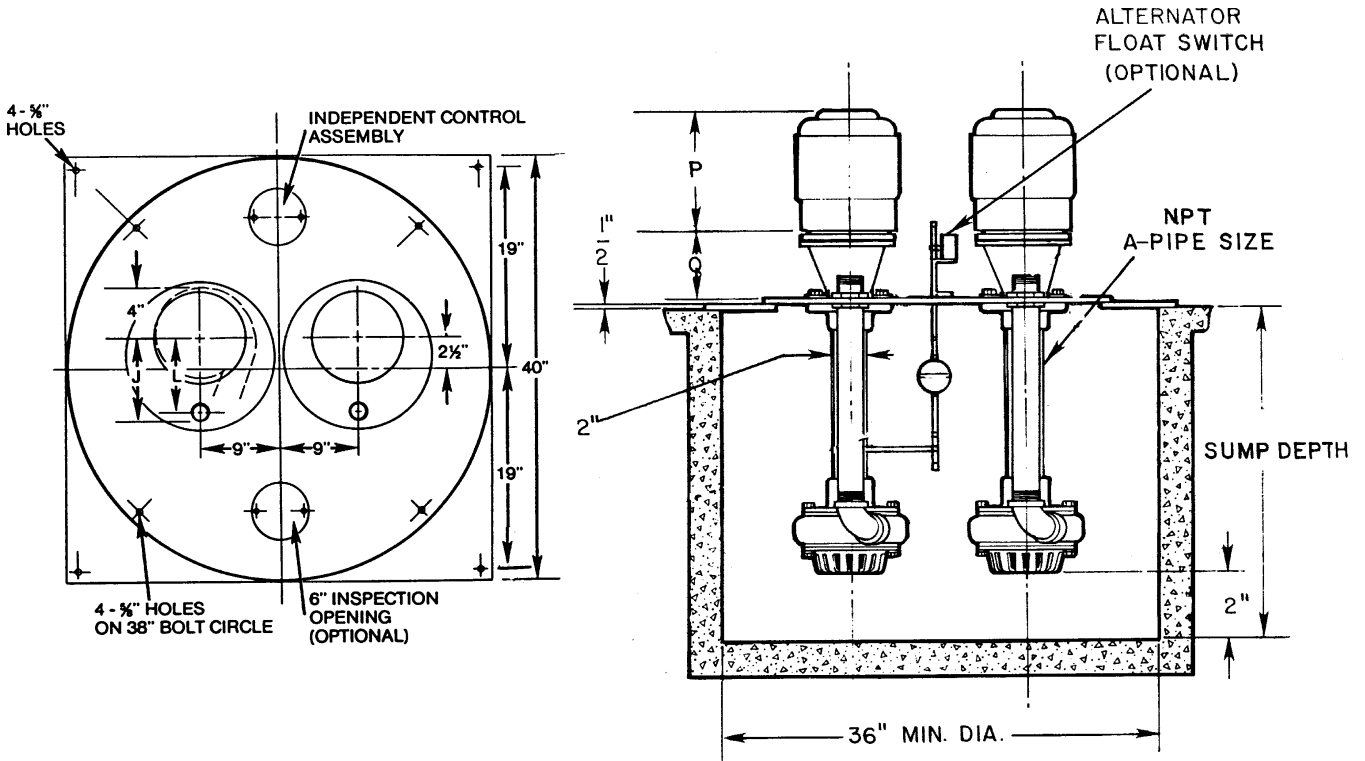

PUMP DATA

SIZE	A	C	J	L
1 1/2 x 1 x 6	1	2 to 12 Feet*	7 1/2	6 1/2
	1 1/2		8 1/4	7
2 x 1 1/2 x 6	1 1/2		8 1/2	7 1/4
	2		9 1/4	7 3/4

MOTOR DATA

FRAME	P	Q
56 C	12 1/8	5 5/8
143 TC - 145TC	12 1/4	5 5/8
182TC - 184TC	15 7/16	6 3/8
213TC - 215TC	16 1 1/16	6 3/8

* Sump Depth is in 1 Foot Increments

Not for construction unless certified, some dimensions may vary $\pm 1/2"$. Pump Construction: _____

CUSTOMER _____ CUSTOMER NO. _____
 PROJECT _____ SERIAL NO. _____
 ENGINEER _____ LOCATION _____
 CONTRACTOR _____
 PUMP Model Size Curve No. GPM Head SP. GR. @Temp. Pump Length Plate
 DATA _____
 MOTOR Mfg. HP RPM Volt-Phase-Cycle Frame ENC. Furnished by Mounted by
 DATA _____
 Shop Order _____ Certified by _____ Date _____