

1. Flexible Coupling

2. External Impeller Adjustment

High performance maintained without dismantling pump

3. Bearings

All bearings are located above the floor plate. Moisture-proof enclosure with (2) grease seals, purge type grease lubrication. Extra heavy construction incorporating long bearing span for increased shaft rigidity and long pump life.

4. Direct or Belt Drives

Direct drive with standard Nema "C" face motor- Belt drive with standard "T" frame motor mounting also available

5. Shafting

Rugged alloy accurately machined with taper to precision tolerances

6. Column

Heavy duty steel with welded flanges

7. Shaft Sleeve (optional)

Protects shaft from abrasive particles at the throttle area

8 Positive Machined Fits

Rabbit fit to assure positive alignment throughout pump construction

9. Impeller

Semi-open centrifugal design with balance ring and eductor vanes

10. Casing

Sizes 4 X 3 X 10 and larger are double volute. Heavy wall thickness for corrosion allowance

Typical Cross Section

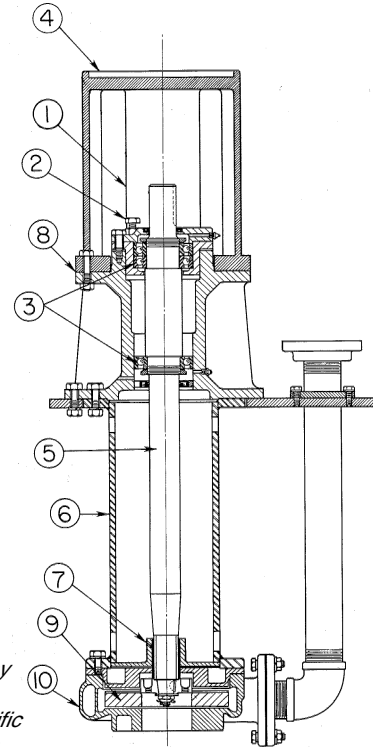

Materials of Construction

Part Description	All Iron	316 Stainless Fitted	All 316 Stainless	Alloy 20
Support Head	Steel or Cast iron	Steel or Cast Iron	Steel or Cast Iron	Steel or Cast Iron
Thrust Bearing Housing, Bearing Cap	Steel	Steel	Steel	Steel
Thrust Bearing, Radial Bearing	Steel	Steel	Steel	Steel
Lip Seals	Nitrile	Nitrile	Nitrile	Nitrile
Shaft	Steel C1144	Stainless Steel AISI-316	Stainless Steel AISI-316	Alloy 20
Shaft Sleeve (optional)	Stainless Steel AISI-316	Stainless Steel AISI-316	Stainless Steel AISI-316	Alloy 20
Impeller Nut	Stainless Steel AISI-316	Stainless Steel AISI-316	Stainless Steel AISI-316	Alloy 20
Case Adaptor	Steel	Steel	Stainless Steel AISI-316	Alloy 20
Impeller	Cast Iron Class-30	Stainless Steel AISI-316	Stainless Steel AISI-316	Alloy 20
Casing	Cast Iron Class 30	Cast Iron Class 30	Stainless Steel AISI-316	Alloy 20
Column, Discharge Pipe, Discharge Elbow	Steel	Steel	Stainless Steel AISI-316	Alloy 20