

VERIFLO PUMP COMPANY Dimensions

1400 Series - Base-Mounted Model 1434

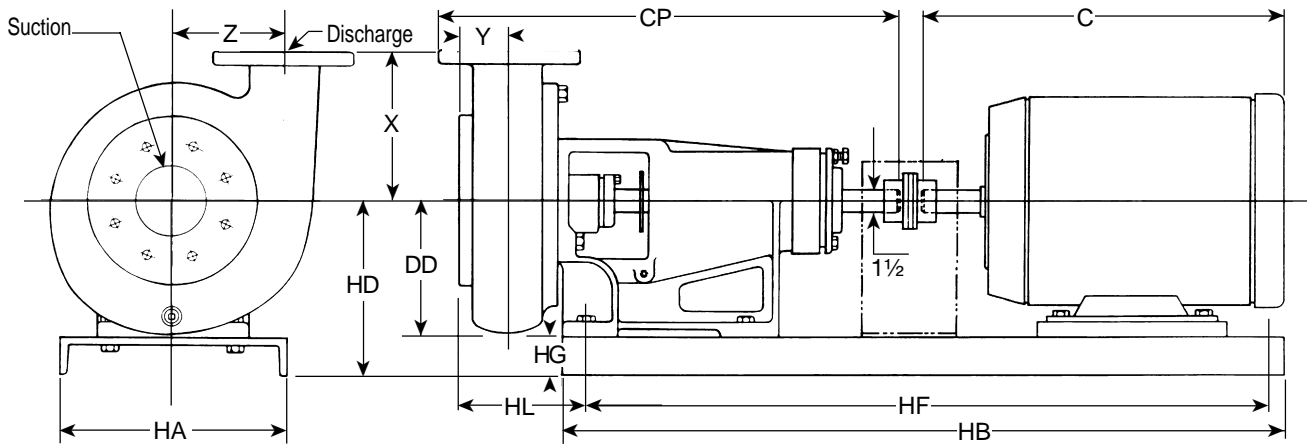

Pump Size	SUCTION				DISCHARGE				X	Y	Z	CP	DD	HS
	Size	DIA. FLG.	Bolts	BC	Size	DIA. FLG.	Bolts	BC.						
6x4x12	6	11	8-3/4	9 1/2	4	9	8-5/8	7 1/2	9	2 3/4	7 3/4	28 1/8	9	7 1/8
6x4x12A	6	11	8-3/4	9 1/2	4	9	8-5/8	7 1/2	9	2 3/4	7 3/4	28 1/8	9	7 1/8
6x6x12	6	11	8-3/4	9 1/2	6	11	8-3/4	9 1/2	9	3 1/4	8 3/8	28 7/8	10 1/4	7 7/8
8x8x12	8	13 1/2	8-3/4	11 3/4	8	13 1/2	8-3/4	11 1/4	11	4 1/2	10 1/2	30 3/8	13 3/8	9 3/8
10x10x12	10	16	12-7/8	14 1/4	10	16	12-7/8	14 1/4	11	5 1/2	10 5/8	32 3/8	13 3/4	11 3/8

Frame Size	213T	215T	254T	256T	284TS	284T	286TS	286T	324TS	324T	326TS	326T	364TS	364T	365TS	365T	404TS	404T	405TS	405T
C	17 3/4	19 1/4	22 7/8	24 5/8	24 1/2	25 7/8	26	27 3/8	27 1/4	28 3/4	28 3/4	30 1/4	31	33 3/8	32	34 7/8	34 1/4	37 1/4	36	38 7/8
HA	15	15	15	15	15	15	15	15	18	18	18	18	18	18	18	18	25	25	25	25
HB	40	40	43	47	47	47	47	47	51	51	51	51	51	51	51	51	50	57	50	57
HD	12 3/8	12 3/8	12 3/8	12 3/8	12 3/8	12 3/8	12 3/8	12 3/8	13	13	13	13	13	13	13	13	15 1/2	15 1/2	15 1/2	15 1/2
HD 8x8x12	14 3/8	14 3/8	14 3/8	14 3/8	14 3/8	14 3/8	14 3/8	14 3/8	15	15	15	15	15	15	15	15	15 1/2	15 1/2	15 1/2	15 1/2
HD 10x10x12	14 3/8	14 3/8	14 3/8	14 3/8	14 3/8	14 3/8	14 3/8	14 3/8	15	15	15	15	15	15	15	15	15 1/2	15 1/2	15 1/2	15 1/2
HF	37 1/2	37 1/2	40 1/2	44 1/2	44 1/2	44 1/2	44 1/2	44 1/2	48 1/2	48 1/2	48 1/2	48 1/2	48 1/2	48 1/2	48 1/2	48 1/2	47	54	47	54
HG	3 3/8	3 3/8	3 3/8	3 3/8	3 3/8	3 3/8	3 3/8	3 3/8	4	4	4	4	4	4	4	4	4 1/2	4 1/2	4 1/2	4 1/2

Performance at Casing Discharge Flange

Curves Show Performance with Liquid Having Specific Gravity 1.0 Viscosity • 30 SSU

CUSTOMER _____ CUSTOMER NO. _____

PROJECT _____

ENGINEER _____

CONTRACTOR _____

CONDITIONS: _____ GPM _____ TDH _____ HP _____ EFF% _____ IMP. DIA _____